



www.arcaudio.com

FD2100 FD2200 FD4100 FD4150

OWNER'S MANUAL

High Performance Audio Amplifier



LIMITED WARRANTY

Before shipping this product back for service call for a Return Authorization number. This number must be clearly marked on the outside of the box.

Terms & Conditions: ARC Audio warrants this unit to be free of any material defects or defects in workmanship for a period of one year and will repair, replace or replace with remanufactured goods at its discretion this unit or any part thereof only if it proves to be defective as a result of normal use.

Our obligation under this warranty is limited to the defective components of the unit thereof when it is returned, shipping prepaid, to ARC Audio.

This warranty is to be considered void if the unit has been tampered with, connected contrary to the installation instructions in the owner's manual, altered, damaged by improper input voltages or polarity, defaced, or treated in a negligent manner.

All returns must be sent freight prepaid and must be accompanied by proof of purchase or they will be treated as "OUT of WARRANTY" and will only be repaired at the owner's expense. All warranties, expressed or implied shall be void if the serial is removed or defaced.

Out of warranty service is available after the warranty expires. Cost of repair is based on current repair labor rates, plus the cost of shipping and handling. When returning for repair, pack the unit securely and send prepaid and insured to the address below. ARC Audio is not responsible for damage incurred during shipping.

For warranty and non-warranty repairs, send to:

**ARC Audio
4719 Green Leaf Cr. #4
Modesto CA, 95356
209-543-8706**



www.arcaudio.com

Congratulations!

Thank you for purchasing an ARC Audio Hi-Performance Amplifier.

ARC Audio amplifiers are conservatively rated and produce more power per channel than others in their class. Manufactured to the highest standards of quality and reliability to deliver years of listening enjoyment.

ARC Audio...**SOLID CONSTRUCTION for SOUND Car Audio Systems.**

Warning

We build all ARC Audio products to play at high volumes for extended periods of time. Your ears however are not designed for high volume listening. This product can easily generate volumes that can permanently damage your hearing. We urge you to limit your exposure to very high volume sound.

You may also find your state has laws governing the volume of an audio system in a car. Please be aware of all local and state laws in your area.

A properly tuned and operated audio system will deliver years of enjoyment when used properly.

Installation Instructions

ARC Audio FD Series Amplifiers are designed for easy installation in your vehicle. To ensure proper operation of your new purchase, please follow the suggestions we have listed below:

Warning

Please check the suitability of the installation location before you begin. Do not cut any of the car's structure. Pay close attention to what is behind the panels or carpet. Often the manufacture will hide wires, computers or other electronic devices in the exact areas you wish to install in.

If you do not have experience with automotive electrical and mechanical systems contact a professional installer. Paying a qualified installer is almost always cheaper than paying a dealership to repair your car.

Locating the Amplifier

The amplifiers must be securely mounted to a solid surface. Please select a dry location in the trunk or passenger compartment only. Do not mount the amplifier to any area that may have excess vibration (like the subwoofer box). Position the amplifier in an area that receives sufficient airflow for proper heat dissipation.

Supplying Enough Power

The Laws of Nature

Your amplifier Does NOT make power. It converts power, or current, from your cars electrical system and turns it into a high power musical energy. If the amp can't get all the power it needs it will not produce its full output. Your ARC Audio amplifier will produce Full output for longer than other amps on the market today. If the Voltage or Current drops too low even our amplifiers will drop below their rated output. Make sure your vehicle charging system is in good working order. Any Hi-Performance audio amplifier will increase the demand on your alternator and battery. If you are unsure have your charging system tested by a professional technician.

The Ground!!!

Warning: Read this Carefully

The ground wire should be connected directly to the chassis of your vehicle. Find a clear location close to the amplifier and remove all the paint and sound deadener. Use a #10 or larger screw to secure it. Never use seatbelt bolts for grounding.

Remember, the ground must carry the same high current as the positive power wire. It is recommended in high power application that you upgrade your vehicles factory battery ground lead to the frame and engine grounding points to ensure the best possible circuit to allow you to receive all of the power benefits your new amplifier has to offer.

To reduce the risk of noise, run all signal cable from any vehicle or power supply wiring.

Running the Cables

Carefully run the power and signal cables through the passenger compartment of the vehicle. Always make sure to use an insulated grommet to prevent the power wire from shorting when passing any cables thru a metal panel and to reduce the risk of fire. Always use the proper size power wiring when installing your new amplifier. Depending on the size of your amplifier a 4 gauge or larger wire should be used for power and ground connections. It is also advised and recommended that a fuse be installed on the power wire within 18 inches of the battery or power source for safety.

Setting the Gains

So you're worried that your 4 Volt output head unit will be too much for the ARC Audio's 2.5 Volt input stage.

Don't Be

ARC Audio Amplifiers input stage is rated to 2.5 volts RMS @ 1KHz without clipping.

Music is very dynamic. Nothing like a 1KHz test tone. It would be rare to see a peak as high as a test tone. Furthermore, your head unit produces its output at full volume but when you tune your system you always set the head unit to 70% of maximum volume.

Input Section

Because of the wide range of head unit output configurations all ARC Audio amplifiers have an adjustable input sensitivity or "Gain". The gain is not a volume or a power limiting control like a throttle. It makes the amp more sensitive to input from the stereo. With the gain up the amp will reach full output at a lower volume setting on the deck. At higher gain settings the amp also becomes more sensitive to noise from the car's electrical system. Try to run the gain at the lowest setting possible for you system.

There is no correct gain setting. Because speakers require different power demands to reach the same output, the gains most often need to be used to compensate for these differences. If you tried to set all the gains at half way you would probably find the system didn't sound very good. Using good judgment and listening carefully to each speaker is still the best way to tune a system.

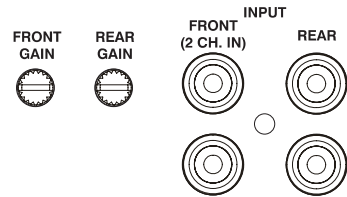

Input Mode Switch

All ARC Audio amplifiers include an input mode switch. This switch controls the signal being sent to the amplifier sections. Most 2-channel amplifiers can be bridged into a single channel however if the signal to the channels is not exactly the distortion will increase significantly. The mode switch solves this problem by offering 3 modes of operation.

Stereo

This is simple 2 channel stereo operation. Use this setting for most applications that do not involve bridging the output.

Bridge (R IN)

On a 2-channel amp only the Right channel input will be split and sent to both outputs. You need only use the Right gain. On a 4 channel the right RCA will be sent to the front outputs. The left RCA will be sent to the rear outputs. This is a great way of get high power to a component set. The amplifier now acts like a 2 channel that makes full power at 4 ohms.

L+R SUM MONO

This is the mode for bridging a subwoofer. Both the left and right channels are combined into a mono signal that is then split and sent to both output. This will give you a true mono output.

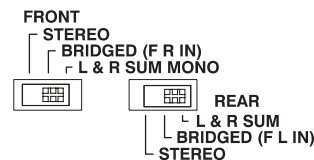

Crossover Controls

A crossover is a device that removes unwanted frequencies from a speaker or amplifier. A tweeter can easily be destroyed by bass notes if they are not filtered out. Likewise a subwoofer will not sound natural if it is playing midrange notes. A crossover removes these sounds from the speaker. As you might guess, careful adjustment is need to ensure that all the speakers are playing the right sounds and that you are left with no "holes" or low spots in the frequency response.

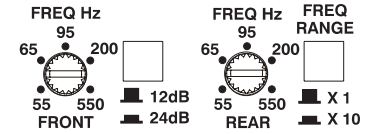

Bass Boost

This amp has a fully adjustable bass boost. Both the frequency and the level of the boost are adjustable. Start with a small increase in the level control. Then "sweep" the frequency up and down. Listen carefully for an improvement in the sound of the bass. If you do not hear any improvement then the woofer does not need any boost.

Use Bass Boost carefully. The demands on power output are tremendous. Try to minimize the use by changing woofer position or the enclosure size.

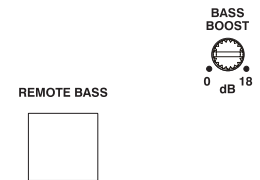

Speaker outputs

This amplifier is a multi channel amplifier design. Meaning it has more than one channel of speaker outputs. It is equipped with a large block style terminal for speaker connection. Make this connection carefully and neatly. Strip your wire back and twist the exposed leads and insert into the block terminal while being careful that there is no loose or frayed strands of wire and tighten the Phillips head screw down on the terminal till the wire is tightly secured in place. If the wires ever come in contact with each other the amplifier will go into protection.

Know your total ohm load before you make any connections.

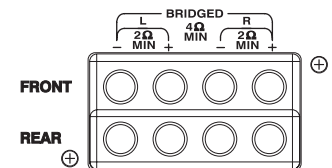

Installation Instructions

1. Disconnect the negative cable from the car battery. Tape up the end so it is isolated from the battery.
2. Run an 8 AWG power wire (4 AWG min. for FD4150 or if you are using multiple amplifiers) from the battery to the amplifier. Plan this part of the installation carefully. This cable will carry very high current. If it should short to the body and it is not properly fused it could catch fire.
3. Connect the power wire to the battery using a fuse capable of the total current load of all amplifiers connected. Don't install the fuse yet. Wait until the end. Locate the fuse as close as possible to the battery. If the fuse is further than 18 inches (wire length) from the battery you should reevaluate the wire and fuse placement.
4. Find the closest clear metal area to the amp for a ground. Sand, grind or scrape all paint and undercoating from the body and screw the ground securely to the body.

It is advisable to test the ground with an ohmmeter between the ground cable and the negative battery cable to insure a good low resistance connection. Some alloys used in modern cars do not offer the best ground. If you believe this is the case consult with the vehicle manufacturer.

5. Run the speaker wire to the speakers. It is advised that you leave some extra wire at this point. You can "clean it up" later.
6. If you haven't already done so, mount the amp now.
7. Connect the power and ground to the amplifier.

Only after this step should you install the fuse at the battery.

8. Connect the remote wire from the head unit to the amplifier. Now is a good time to turn on the amp for the first time. Make sure it turns on properly and does not go into protect.

9. Connect the speaker wire to the amp and speakers (make sure the amp is off first). Make sure the polarity (+ and-) is correct.
10. Connect the RCA's to the amp.
11. Double check the amplifier controls at this time. Make sure everything is set correctly for your system.
12. Now you're ready to play it for the first time. It is best to leave the gain all the way down at first. Start with the head unit volume low and work your way up.
13. Now you can tune the amp. Take your time and make only one adjustment at a time. It may take some time to get the system fully adjusted. During this time the amp is drawing current from the battery. You should check the battery voltage from time to time and re-charge it if it gets low. Battery voltage can affect the way the amplifier performs.
14. You're done. Now have fun.

FD2100 and FD2200
BRIDGED 4 OHMS

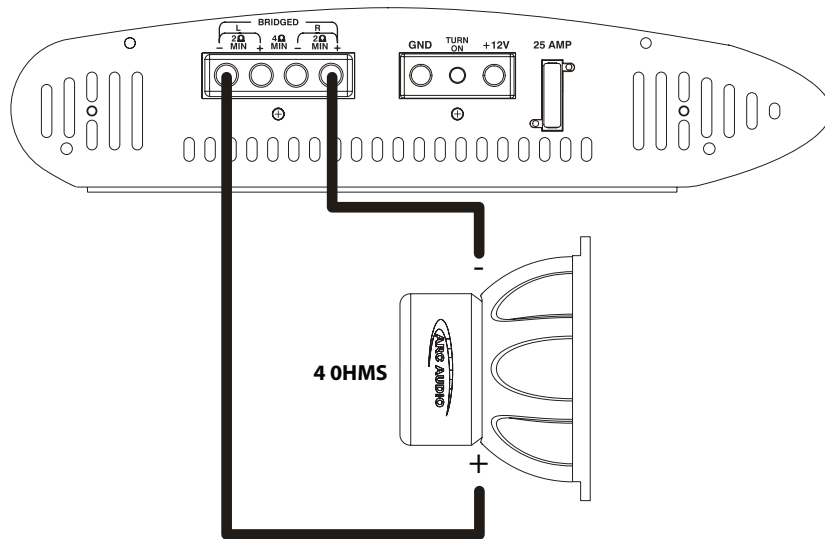
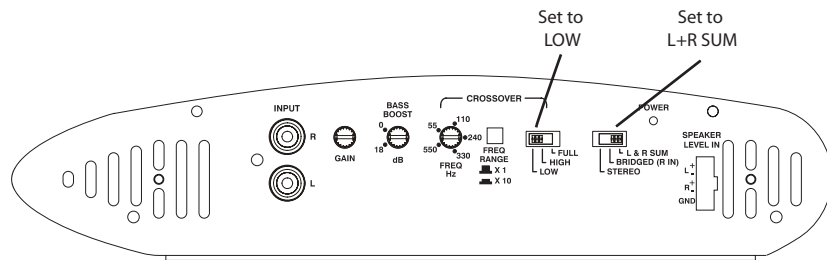

FD2100 and FD2200
STEREO FULL RANGE OR HIGH PASS
4 OHMS/2 OHMS

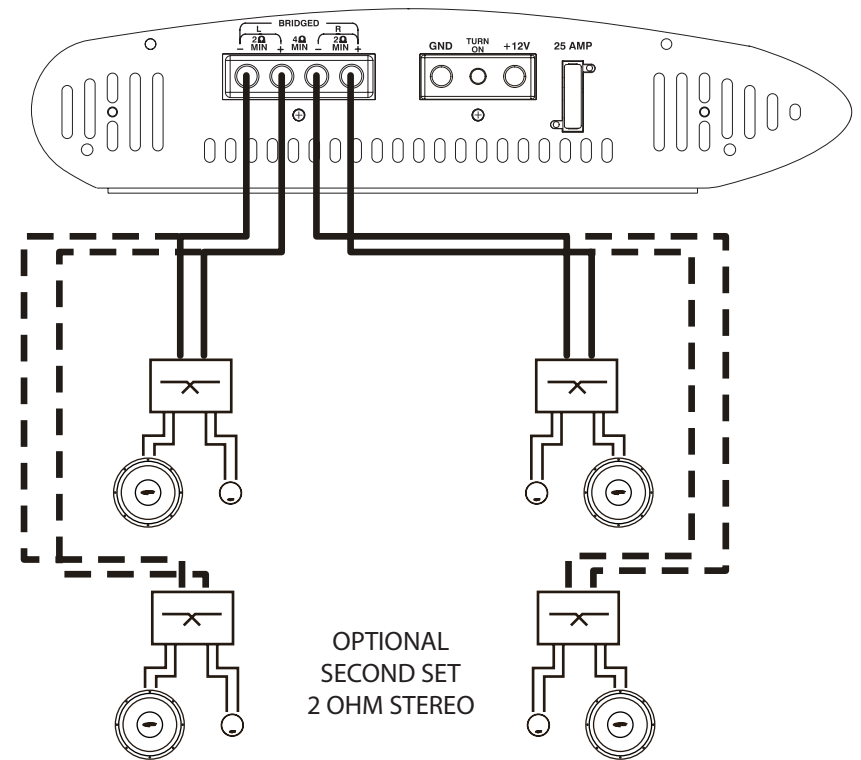
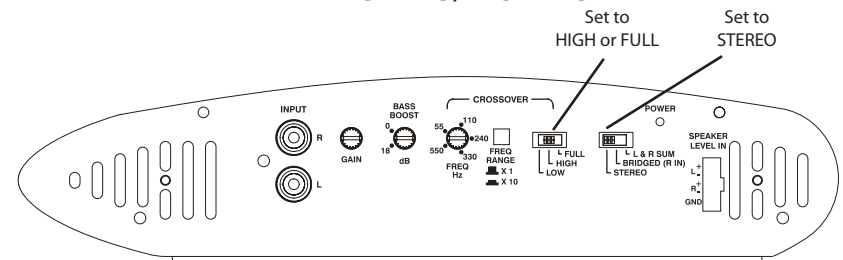

FD4100 and FD4150 STEREO 4 CHANNEL HIGH PASS

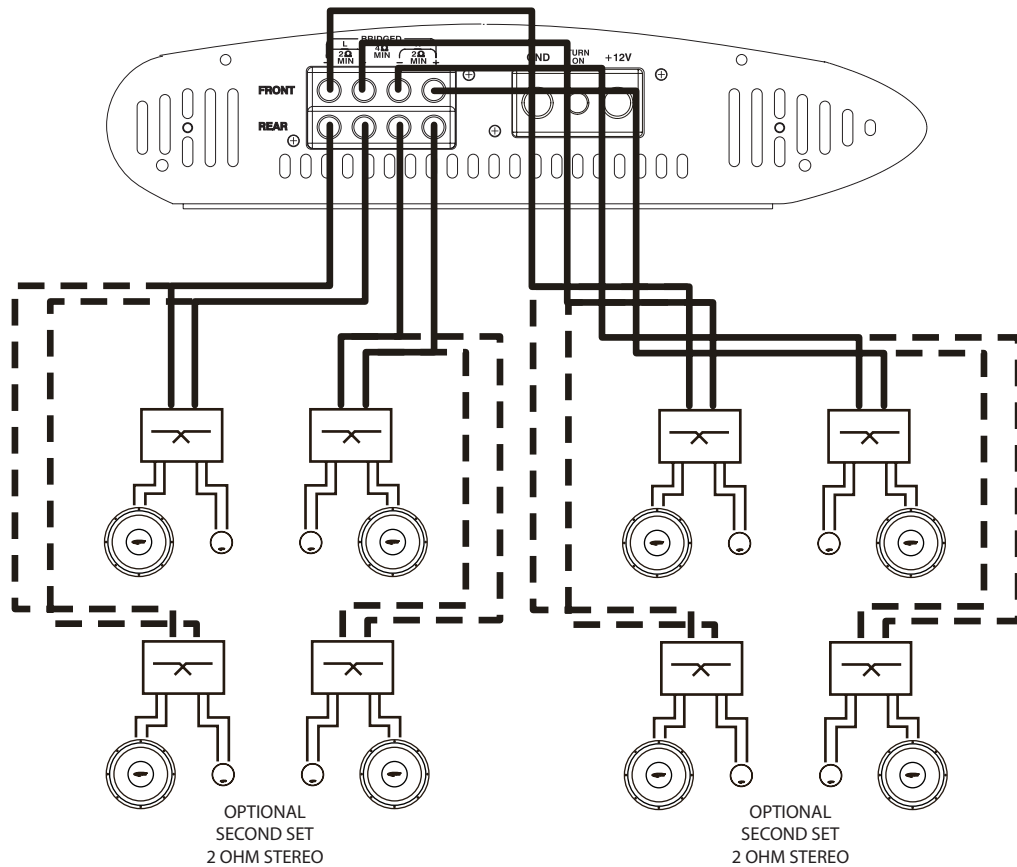
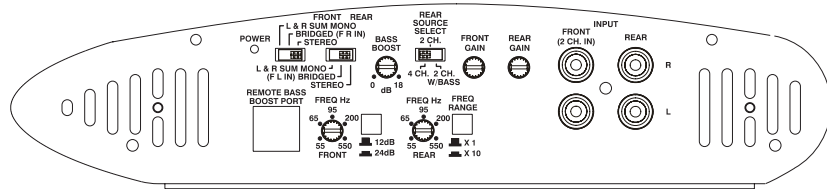

FD4100 and FD4150 STEREO FULL RANGE OR HIGH PASS With MONO SUBWOOFER

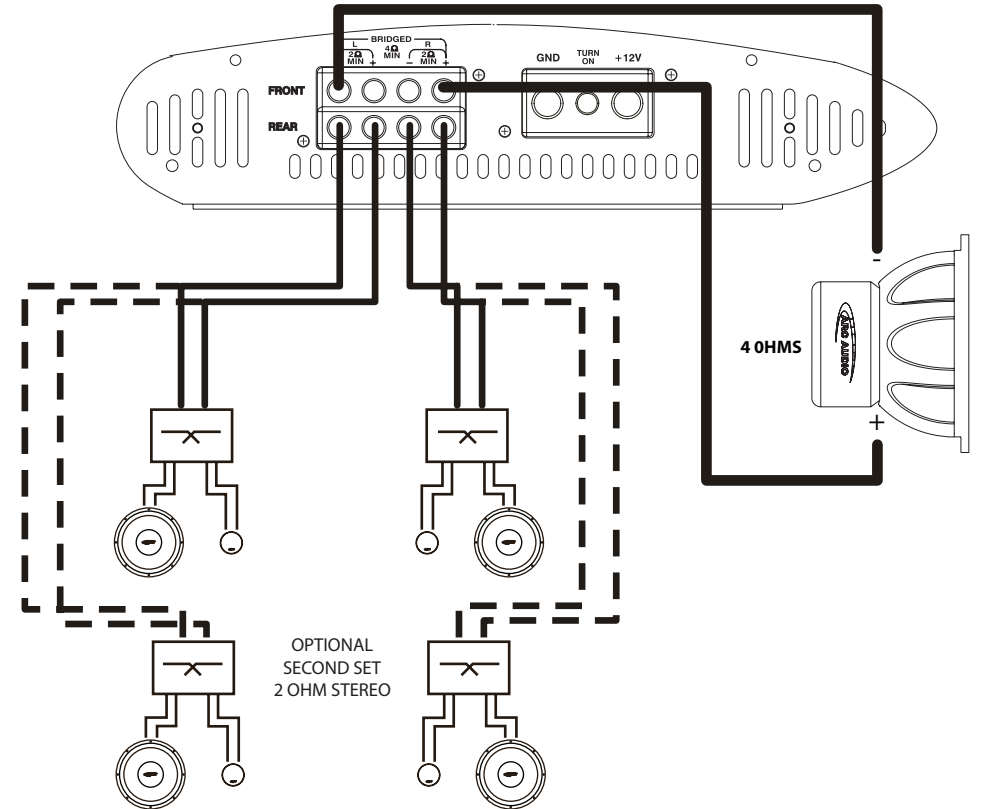
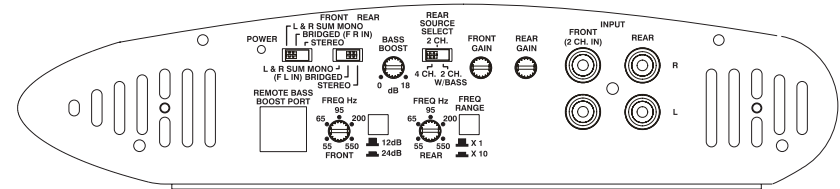

FD4100 and FD4150 STEREO 4 CHANNEL

SET BOTH INPUT SWITCHES TO
"BRIDGED"

HIGH PASS

Use the Front inputs, Front gain
and Front Crossover only

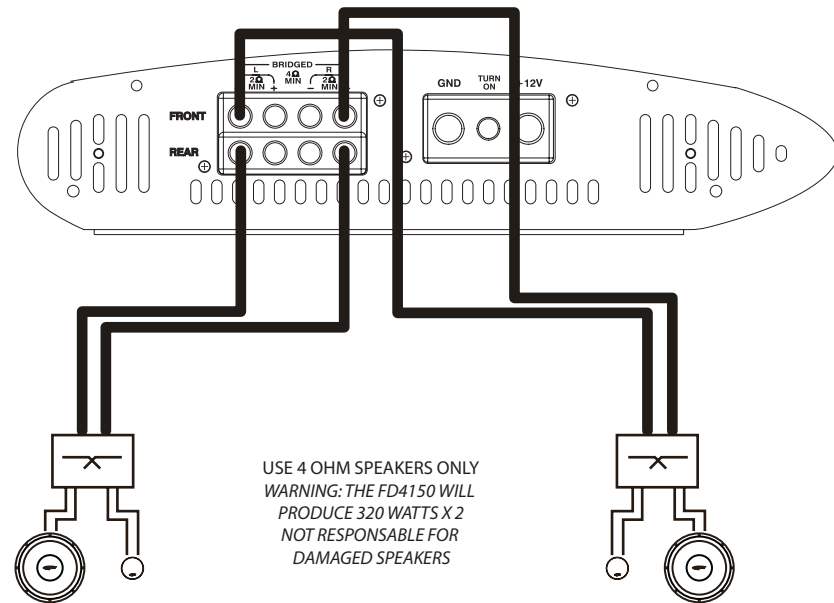
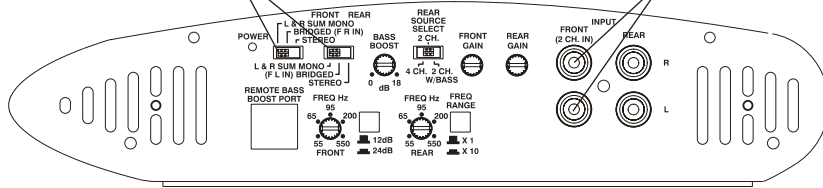

FD4100 and FD4150 2 CHANNEL BRIDGED

SET BOTH INPUT SWITCHES TO
"BRIDGED"

LOW PASS

Use the Front inputs, Front gain
and Front Crossover only

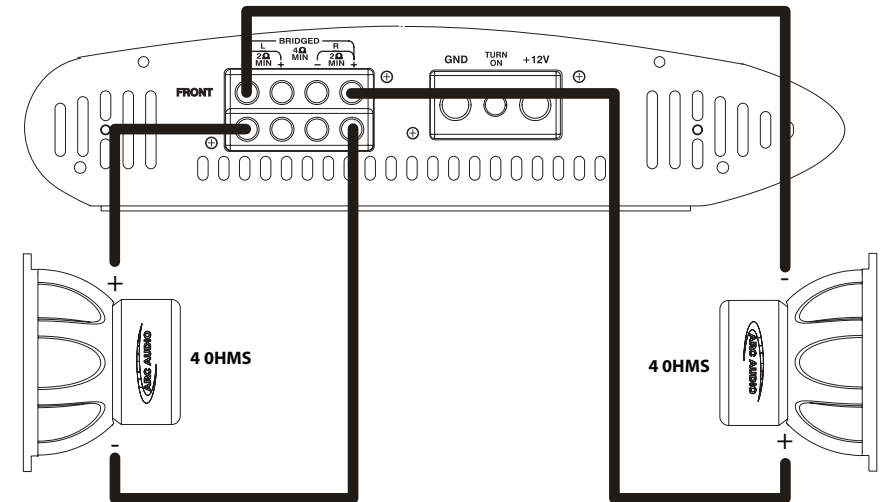
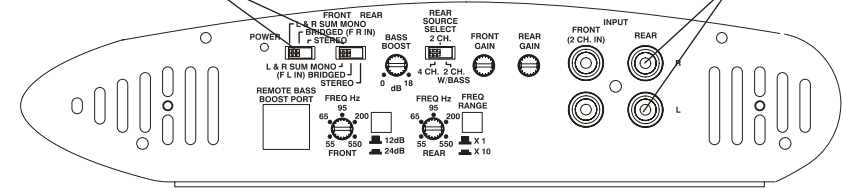

POWER AND INPUT CONNECTIONS

DUAL BATTERY or BATTERY AND CAPACITOR

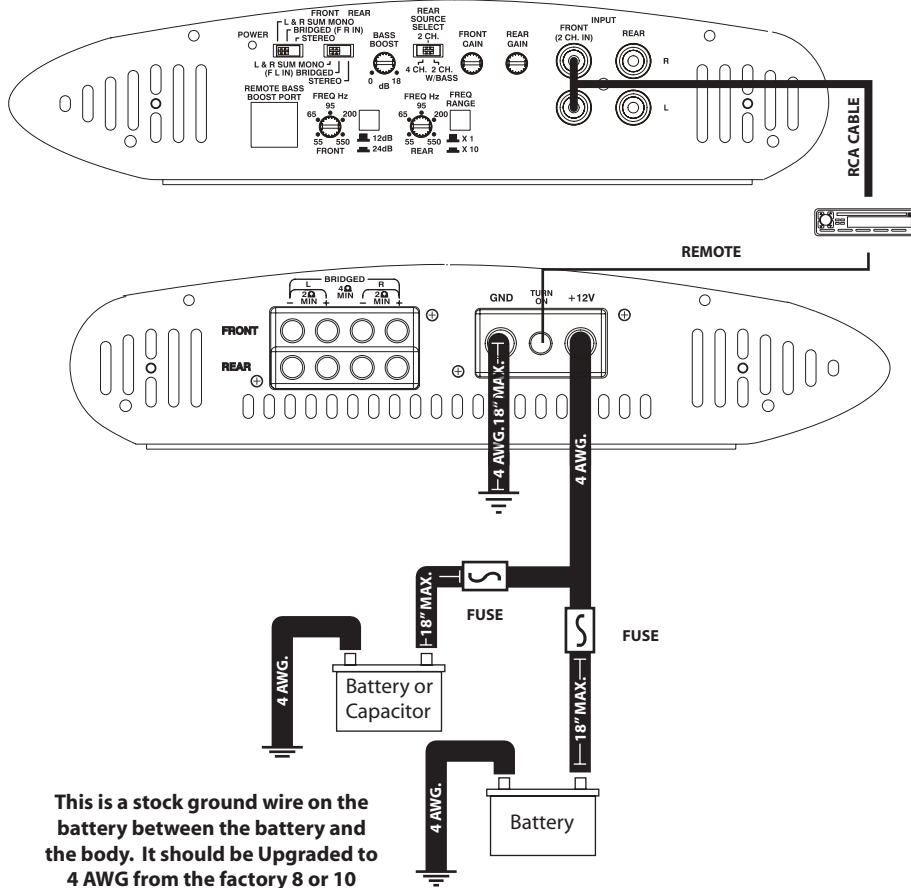

This is a stock ground wire on the battery between the battery and the body. It should be Upgraded to 4 AWG from the factory 8 or 10 AWG.

POWER AND INPUT CONNECTIONS

SINGLE BATTERY

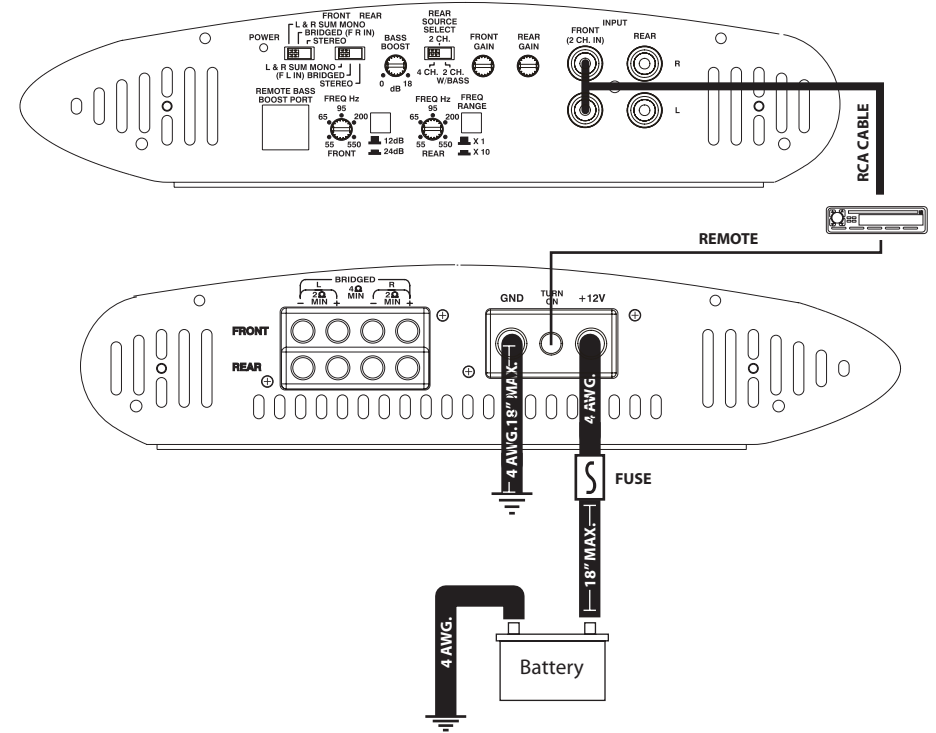

This is a stock ground wire on the battery between the battery and the body. It should be Upgraded to 4 AWG from the factory 8 or 10 AWG.

Specifications

FD4100

FD4150

4 Channels @ 4Ohms 4 Channels @ 2Ohms 4 Channels @ 1Ohm 2 Channels @ 4Ohms 2 Channels @ 2Ohms	50 Watts 90 Watts NOT RECOMMENDED 180 Watts NOT RECOMMENDED	80 Watts 160 Watts NOT RECOMMENDED 320 Watts NOT RECOMMENDED
Frequency Response Crossover Range Bass Boost	20 Hz > 30kHz 55Hz - 550Hz (x10 550Hz - 5500Hz) 0 - 18dB @ 45Hz	20 Hz > 30kHz 55Hz - 550Hz (x10 55Hz - 5500Hz) 0 - 18dB @ 45Hz
S/N Ratio (A wtg) ref 1Watt 40hm Seperation @ 1kHz Damping (25W 4x40hm 100Hz)	>95 dB >65 dB >800	>105 dB >75 dB > 1600
Low Level Input Sensitivity Max Peak Current 20hm Stereo Dimensions	.25V - 2.5V 46A @ 380Watts 10 3/8" X 16 1/2" X 2 3/8"	.25V - 2.5V 82A @ 640Watts 10 3/8" X 21 3/4" X 2 3/8"

Output Power (RMS) @ .05% 1000Hz 14.4v Input

FD2100

FD2200

2 Channels @ 4Ohms 2 Channels @ 2Ohms 2 Channels @ 1Ohm	50 Watts 95 Watts NOT RECOMMENDED	100 Watts 185 Watts NOT RECOMMENDED
Frequency Response Crossover Range Bass Boost	20 Hz > 30kHz 55Hz - 550Hz (x10 550Hz - 5500Hz) 0 - 18dB @ 45Hz	20 Hz > 30kHz 55Hz - 550Hz (x10 55Hz - 5500Hz) 0 - 18dB @ 45Hz
S/N Ratio (A wtg) ref 1Watt 40hm Seperation @ 1kHz Damping (25W 4x40hm 100Hz)	>100 dB >75 dB >800	>98 dB >72 dB > 800
Low Level Input Sensitivity Max Peak Current 20hm Stereo Dimensions	.25V - 2.5V 28A @ 380Watts 10 3/8" X 13" X 2 3/8"	.25V - 2.5V 42A @ 380Watts 10 3/8" X 15 1/2" X 2 3/8"

Output Power (RMS) @ .05% 1000Hz 14.4v Input

Troubleshooting

Problem

No Audio.

Solution

Low or no remote turn-on voltage. Check remote connections at amplifier and source unit.

Blown amplifier fuse. Replace with new fast-blow fuse (same rating).

Power wires not connected. Check battery and ground wiring at amplifier; also check battery connections.

Speaker leads shorted. Check speaker continuity to ground, it should not show a common ground.

Problem

Audio cycles on and off.

Solution

Thermal protection circuits are shutting amplifier off. Check location for adequate ventilation; consult an authorized ARC Audio Dealer.

Problem

Distorted audio.

Solution

Gain is not set properly, or damaged speaker cones. Review Setting Gain; inspect each speaker cone for signs of damage (i.e. frozen cone, burning smell, etc.)

Notes

It is recommended that you record your system configuration for later use. You may find it helpful to write down your gain and crossover setting. You may also wish to staple a copy of your sales receipt here.

Serial Number _____